



actual size

Programmed Oscillator · JPO32 · 3.3/2.5/1.8 V

Programmed SMD CMOS Oscillator · 3.2 x 2.5 mm

- fast delivery service
- tristate or stop function available
- reflow soldering temperature: 260 °C max.
- RoHS compliant, ceramic/metal package



General Data

type		JPO32 3.3 V / 2.5 V / 1.8 V
frequency range		3.0 ~ 200.0 MHz (3.3 V, 15 pF) 3.0 ~ 130.0 MHz (2.5 V, 15 pF) 3.0 ~ 100.0 MHz (1.8 V, 15 pF) 3.0 ~ 50.0 MHz (3.3 V / 2.5 V / 1.8 V, 30 pF)
frequency stability over all*		± 25 ppm ~ ± 100 ppm (see table 1)
current consumption		see table 2
supply voltage V _{DC}		3.3 V / 2.5 V / 1.8 V ± 10%
temperature	operating	-20 °C ~ +70 °C / -40 °C ~ +85 °C
	storage	-55 °C ~ +125 °C
output	rise & fall time	see table 3
	load max.	15 pF / 30 pF
	current max.	8 mA (3.3 V) / 4 mA (2.5 V) / 2 mA (1.8 V)
	low level max.	0.4 V
	high level min.	V _{DC} - 0.4 V
standby function		tristate (TRI) / stop (STP)
output enable time max.		100 ns (TRI) / 10 ms (STP)
output disable time max.		250 ns
start-up time max.		10 ms
standby current max.		10 µA (STP version only)
symmetry at 0.5 x V _{DC}		45% ~ 55% typ. (40% ~ 60% max.)

Table 1: Frequency Stability Code

stability code	A	B	G	C
	± 100 ppm	± 50 ppm	± 30 ppm	± 25 ppm
-20 °C ~ +70 °C	○	○	○	○
-40 °C ~ +85 °C	○	○	○	○
○ available				

* includes stability at 25 °C, operating temp. range, supply voltage change, shock and vibration, aging 1st year.

Table 2: Current Consumption max.

frequency range	V _{DC} = 3.3 V	V _{DC} = 2.5 V	V _{DC} = 1.8 V	load
3.0 ~ 50.0 MHz	18 mA	15 mA	8 mA	30 pF
3.0 ~ 100.0 MHz	17 mA	12 mA	8 mA	15 pF
100.0 ~ 130.0 MHz	20 mA	16 mA	–	15 pF
130.0 ~ 200.0 MHz	25 mA	–	–	15 pF

* a ceramics capacitor of 100nF between pin #2 and pin #4 with short distance wiring is strongly recommended

Table 3: Rise & fall time max.

6 ns:	3.0 ~ 50.0 MHz at 30 pF / 1.8 V	note: - specific data on request - rise time: 0.1 V _{DC} ~ 0.9 V _{DC} - fall time: 0.9 V _{DC} ~ 0.1 V _{DC}
5 ns:	3.0 ~ 50.0 MHz at 30 pF / 3.3 V & 2.5 V	
4 ns:	3.0 ~ 100.0 MHz at 15 pF / 3.3 V & 2.5 V & 1.8 V	
3 ns:	100.0 ~ 130.0 MHz at 15 pF / 2.5 V & 3.3 V	
2 ns:	130.0 ~ 200.0 MHz at 15 pF / 3.3 V	

Dimensions

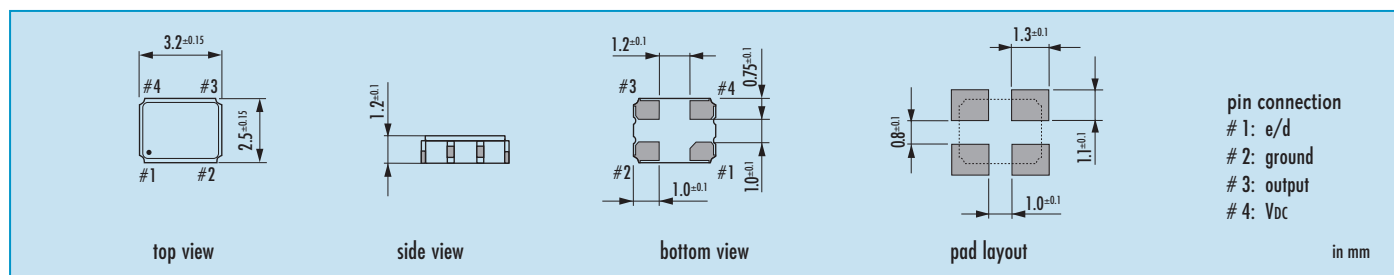

Order Information

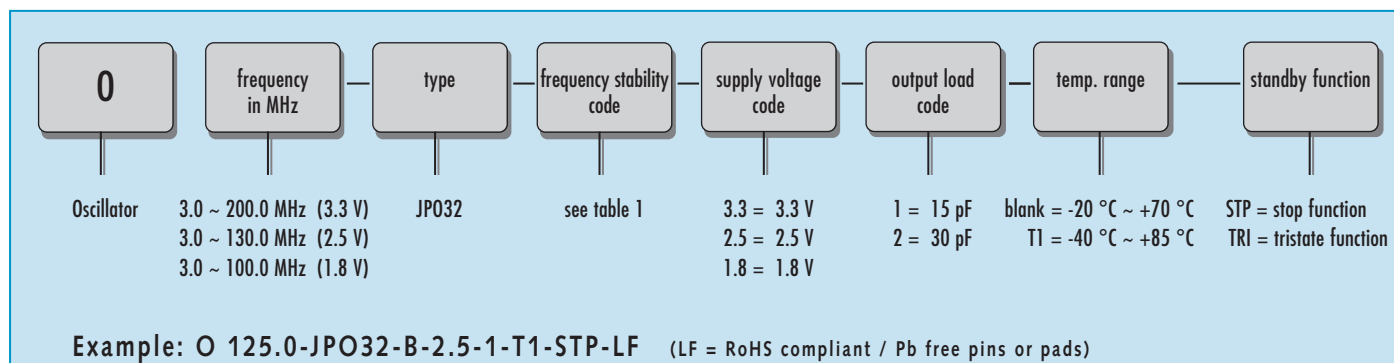

Programmed Oscillator · JPO32 · 3.3/2.5/1.8 V

Taping specification

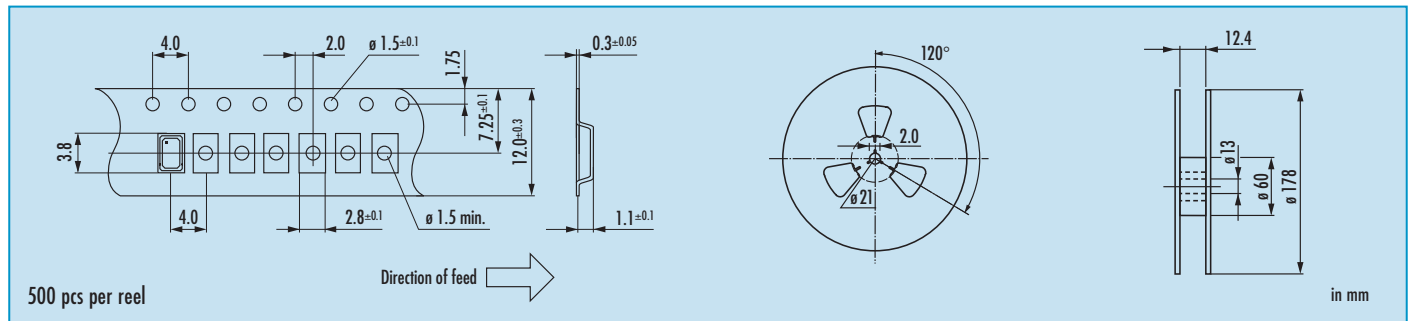

Reflow Soldering Profile

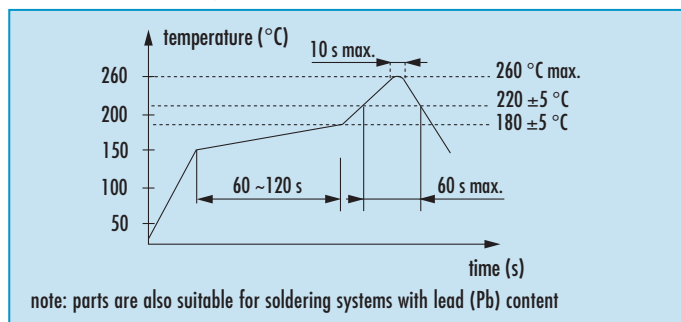

Marking (optional)

JPO / year / month / internal code

date code:

A ~ M: Jan. - Dec.

1: 2011 4: 2014

2: 2012 5: 2015

3: 2013 6: 2016

Jan.	Febr.	Mar.	Apr.	May	June
A	B	C	D	E	F
July	Aug.	Sept.	Oct.	Nov.	Dec.
G	H	J	K	L	M

Packing Note

- standard packing units are 500 pieces per reel
- non-multiple packing units are only supplied taped / bulk

Enable / Disable Function

pin #1 (e/d control)	pin #3 (output, STP)	pin #3 (output, TRI)
open	active	active
high "1" ($V_{IH} \geq 0.7 V_{DC}$)	active	active
low "0" ($V_{IL} \leq 0.3 V_{DC}$)	stop, high impedance	high impedance
	stop (STP) function: • oscillator stops • output high impedance	tristate (TRI) function: • oscillator active • output high impedance